

# TOTAL

One-Stop Tools Station

TOTAL

## JIG SAW

TS206656



# 570W

# Security instructions



## Caution

Read all safety warnings and all instructions. Failure to follow all warnings and instructions can result in electric shock, fire, and / or serious injury.

The term “power tool” in the warnings refers to your mains-operated (corded) power tool or battery-operated (cordless) power tool.

*Note: Save all warnings and instructions for future reference.*

### 1) Work area safety

- a. Keep the work area clean and well lit to avoid accidents.
- b. Do not use power tools in explosive atmospheres, such as in the presence of flammable liquids, gases, or dust that can cause fires.
- c. Keep children and other unauthorized persons away while using a power tool. Distractions can cause you to lose control of the tool.

### 2) Electrical safety

- a. Power tool plugs must match the outlet. Never modify the plug in any way. Using a proper plug reduces the risk of electric shock.
- b. Avoid body contact with grounded surfaces such as pipes, radiators, ranges, and refrigerators. There is an increased risk of electric shock if your body is grounded.
- c. Do not expose power tools to rain or wet conditions. Water entering a power tool will increase the risk of electric shock.
- d. Never use the cord to carry, pull, or unplug the power tool. Keep the cord away from heat or oil.
- e. When using a power tool outdoors, use an extension cord suitable for outdoor use.
- f. If it is unavoidable to use the tool in a humid location, use a residual current device (RCD) protected supply to reduce the risk of electric shock.

### 3) Personal security

- a. Always be alert, watch what you are doing, and use common sense when operating the tool.
- b. Do not use a power tool if you are tired or under the influence of drugs or other substances.
- c. Use personal protective equipment. Always wear eye protection. Protective equipment such as a dust mask, non-slip safety shoes, hard hat, or hearing protection used in the right conditions will reduce personal injury. Also, do not wear loose clothing or jewelry.
- d. Avoid accidentally turning the tool on. Make sure the switch is in the off position before connecting it to the power supply and moving it.
- e. Remove any adjusting key or wrench before turning on the power tool. A wrench or wrench attached to a rotating part of the power tool can cause serious injury.
- f. If dust extraction and collection devices (such as a dust mask) are used, make sure they are connected correctly. Use these devices properly and you will reduce dust hazards.

#### **4) Use and care of power tools**

- a. Do not force the tool. Use the right power tool for each use.
- b. Do not use the power tool if its ignition switch does not work. Any power tool that cannot be controlled with the switch is dangerous and must be repaired.
- c. Disconnect the plug from the power source before making any adjustments, changing accessories, or storing the tool to avoid accidental starting.
- d. Use the power tool, accessories and drill bits, etc. in accordance with these instructions, taking into account the working conditions and the work to be carried out. Using the power tool for operations other than those intended could result in a dangerous situation.
- e. Store power tools out of the reach of children and do not allow anyone unfamiliar with the tool to use it.
- f. Carry out regular maintenance on power tools. Check for misalignment or binding of moving parts, broken parts, and any other conditions that may affect the operation of power tools. If damaged, have power tool repaired before use. Many accidents are caused by poorly maintained power tools.
- g. Keep accessories clean and sharp, as with proper maintenance they are less likely to get stuck and are easier to control.

#### **5) Service**

- a. Have your power tool repaired by a qualified person and use replacement parts recommended by the manufacturer. This will ensure that the safety of the power tool is maintained.

## Safety rules for correct use



Double insulation for additional protection



Read the instruction manual before use.



CE conformity.



Wear safety glasses, hearing protection and a dust mask.



Waste electrical products must not be disposed of with household waste. Please recycle at the appropriate facilities. Check with your local authority or retailer for recycling advice.



Security alert. Use only accessories approved by the manufacturer.

## Other risks

Even when the power tool is used as prescribed, it is not possible to eliminate all residual risk factors:

- Health defects resulting from the emission of vibrations if the power tool is used for a longer period of time or if it is not properly managed and maintained.
- Injury and property damage from broken accessories suddenly breaking.

### Caution

This power tool produces an electromagnetic field during operation. This field can, in some circumstances, interfere with active or passive medical implants.

To reduce the risk of serious injury, we recommend that individuals with medical implants consult their physician before using this power tool.

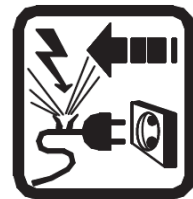

If the cord is damaged or cut during work, do not touch the cord, immediately unplug the tool. Never use the machine with a damaged cord.

The machine must not be damp and must not be used in a humid environment.

### Attention

Safe working with this machine is only possible when the operating or safety information is fully read and the instructions contained therein are strictly followed.



## Technical data

Data sheet	
<b>Voltage</b>	220-240V ~ 50 / 60Hz
<b>Power</b>	570W
<b>No-load speed</b>	800-3000 / min
<b>Wood cutting capacity</b>	65mm
<b>Steel cutting capacity</b>	8mm
<b>Angular cut range</b>	0 ± 45 °
<b>It includes</b>	1 parallel guide 1 hex wrench 1 set of carbon brushes 3 saw blades

## Product description

1. Cutting speed selector
2. Lock switch
3. Trigger
4. Dust collector
5. Motherboard
6. Pendulum action switch
7. Parallel guide
8. Saw holder
9. Saw blade

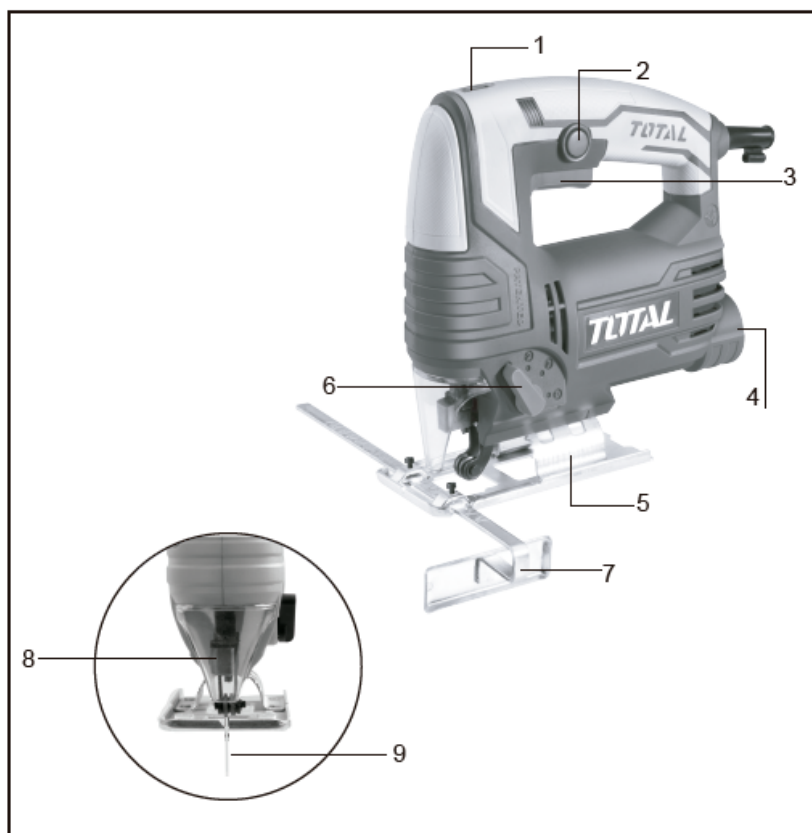

*Note: Not all accessories illustrated or described have to be included in the standard delivery.*

# Set up

## Mounting

### Attaching the saw blade

To change the saw blade, set the pendulum action switch to step "0".

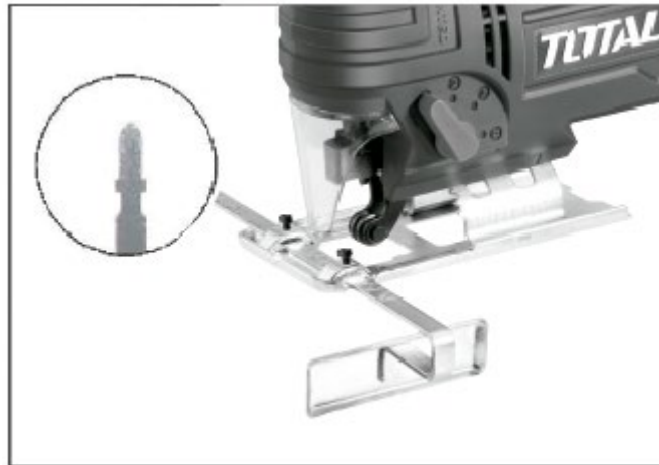

To open the saw holder:

- Turn the ring counterclockwise (jig saw upside down) and hold it in position.
- Fully insert the saw blade into the slot in the saw holder with the teeth forward and release the ring, which will automatically rotate and hold onto the top of the saw blade.
- Push the saw or saw blade into the bracket again to make sure it is locked in position.
- To remove the saw blade:
  - Hold the saw blade
  - Turn the ring counterclockwise
  - Raise the saw blade

*Note: Remove the transparent saw blade guard to facilitate mounting or removal of the saw blades.*



### Attention

The teeth of the saw or saw blade are very sharp. It ejects automatically and quickly, so avoid targeting people.

### Using the parallel guide

The parallel guide allows you to make precise parallel cuts using the metric scale.

- Place the parallel guide in the required position.
- Slide the parallel guide in from the appropriate side (left or right) as appropriate.
- Make sure the guide surface of the parallel guide points downward.



## Start up

### Trigger Switch Operation

To use the pendulum jigsaw:

- Press the trigger switch. If you want to use the pendulum jigsaw continuously, the trigger lock button can be pressed after the trigger is pressed.



### Pendulum action switch setting

The pendulum action of the saw blade, adjustable in four steps, makes possible the optimal adaptation of the advance of the saw or saw blade (cutting speed), the cutting performance and the cutting aspect of the material.

For each downward movement, the saw blade is lifted from the material, facilitating the removal of sawdust, reducing the heat generated by friction, and increasing the life of the saw blade.

At the same time, the reduction in the necessary feed force allows fatigue-free work. The pendulum action switch makes it possible to adjust the pendulum action in four steps. Switching can take place with the machine running.

Pendulum adjustment steps	Material
<b>0: No pendulum action</b>	Rubber, ceramic, aluminum, steel
<b>1: Small pendulum action</b>	Plastic, wood, aluminum
<b>2: Medium pendulum action</b>	Wood
<b>3: Great pendulum action</b>	Wood

Generally, the thinner and cleaner the cutting edge should be, the smaller the pitch of the selected pendulum should be or turn off the pendulum action.

- To work with thin materials such as sheet metal, turn off the pendulum action (step 0).
- On hard material such as steel, work with a small pendulum action.
- On materials such as softwood and cutting in the direction of the grain, the large pendulum action can be used.

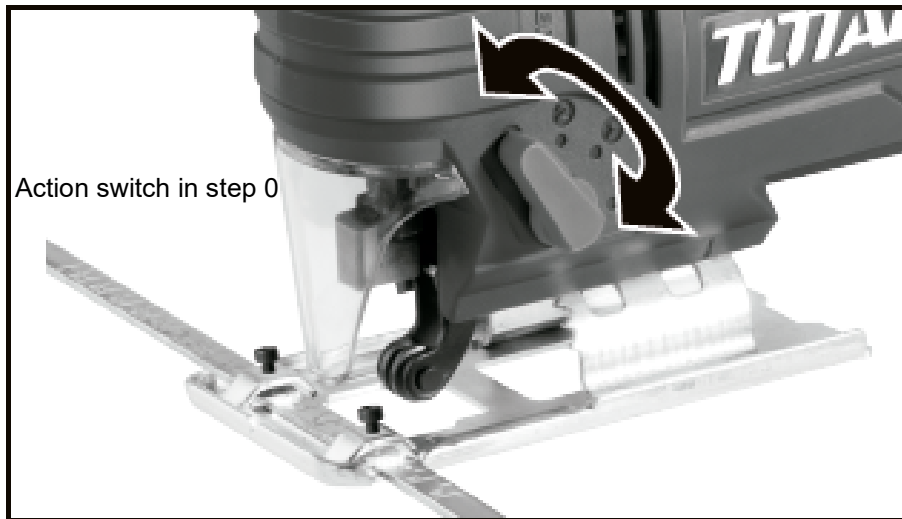

### Cutoff frequency selection

With the thumbwheel, the required cut-off frequency can be selected (also in operation).

- MIN - 2 = Low frequency
- 3 - 4 = Average frequency
- 5 - MAX = High frequency

The required cutting speed depends on the material and working conditions: fast enough to make reasonable progress, but slow enough to maintain a clean cut and avoid stressing the machine.

Generally, thinner saw blades use a higher speed, thicker saw blades use a slower speed.

After working for longer periods at low stroke speed, allow the machine to cool down by running it at maximum stroke speed and no load for approximately 3 minutes.

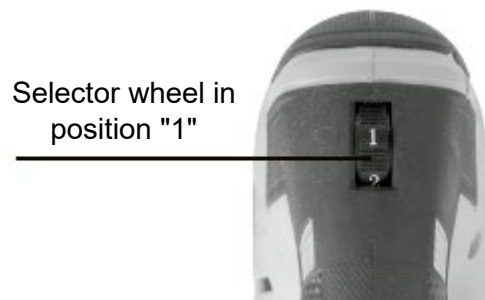



## Using the pendulum jigsaw



### Attention

Before using the saw and connecting the power cord, make sure the trigger switch is in the off position.

- Press the trigger and wait until the blade has reached full speed.
- Place the face of the base plate on the workpiece and align the cut line with the line you want to cut.
- Slowly push forward.
- Keep the base plate flat against the workpiece.

### Metal cutting

A suitable lubricant or similar liquid should always be used (such as light oil, small amounts of soapy water, etc.). If no lubricant or similar liquid is available, grease can be applied to the back surface of the material to be cut.

### Window Slot / Hole Cutting

- For wood:
  - Align the direction of the blade with the grain of the wood.
  - Next, place the rounded portion at the front of the base plate on the surface to be cut, slowly lower the saw into the material at your chosen entry point.
  - Lower the saw in a pivoting action until the blade has cut to the other side, do not move the saw along the intended line of cut until the blade has cut and the base plate is resting on the material.
- For materials other than wood, when cutting window holes first use a drill or similar tool to drill a hole from which the initial cut will begin.



### Adjusting the angle

The angle adjustment screw has been combined with the lever. To adjust the tilt angle, loosen the angle adjustment screw by turning the lever counterclockwise.



Then you can rotate the motherboard to the required angle 0-45 ° to the left or right.

*Note: The tilt angle numbers are stamped on the fan-shaped bracket on the back of the motherboard to help you set the correct angle.*

Check the support roller before tightening. Firmly tighten the angle adjustment screw by turning the lever clockwise to operate.

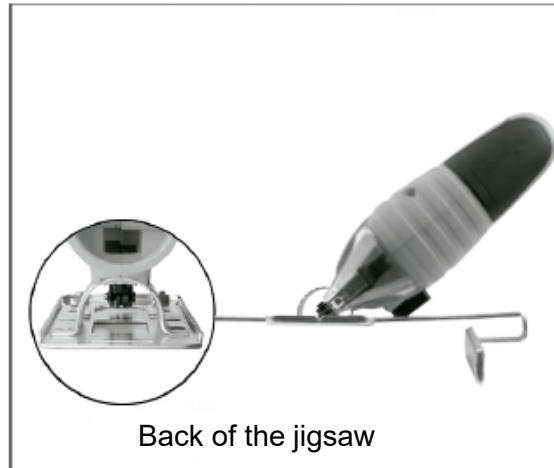

Back of the jigsaw



### Attention

Disengage and position the lever to touch the saw body, or the lever will hit the workpiece.

To achieve sufficient clearance or a good fit of the base plate, you may need to rotate the lever repeatedly when loosening / tightening the angle adjustment screw. The lever has an on / off system.

- Pull the lever back to disengage while the lever is rotated to the leftmost or rightmost position.
- Then reverse the lever, tighten / loosen the screw further as needed.



### Advice on working methods

Here are some tips on controlling pendulum action:

1. The saw blade is only pressed against the material in the return stroke / working stroke. It moves away from the material on the forward stroke. The result is better chip removal, less friction, and therefore higher performance.
2. To prevent the jigsaw from jumping up and down when sewing blades, rest the blade on rafters. When sawing metal, apply a cooling oil along the cut line.
3. Adjust the speed and settings of the pendulum action to suit the material to be sawn. We always recommend that you do a test cut first.
4. To use the jigsaw, place the front end of the base plate on the material and turn on the machine. Press the machine from above onto the material and guide the jigsaw along the cutting line
5. Do not apply too much pressure to achieve the best progress when sawing, apply light pressure on the saw blade.
6. When sawing along a scored line, use the dent guard marking as a guide.

7. For an exact cut, fasten a piece of wood to the material as an aid or use the parallel guide.
8. For miter / bevel, place the base plate in the required position.
9. Place the motherboard in its rearmost position to cut near an edge.

## Maintenance and troubleshooting

### Maintenance

- Clean the jigsaw regularly (remove wood chips and chips, etc.). For best results, do this immediately after the job has been completed.
- Do not allow liquids to enter the jigsaw. Use a soft cloth to clean the case. Do not use gasoline, thinners, or cleaners that can attack plastic.
- Air vents should always be clean and clear.

### Problem solving

- If your jigsaw doesn't work, check the fuse and power at the mains plug.
- If the jigsaw does not cut properly, check the blade and support roller, replace the blade if it is worn. Also check the cutting angle, the blade should be exactly 90 ° to the base plate for normal use.
- If the fault is not found, have the tool repaired at an official dealer.
- There are no user serviceable parts on the jigsaw.

## Environment



- Do not dispose of electrical appliances as unsorted municipal waste, use separate collection facilities.
- Contact your local authority for information on available collection systems.
- If electrical appliances are disposed of in landfills, hazardous substances can seep into groundwater and enter the food chain, damaging your health and well-being.
- Recycle raw materials instead of disposing of them as waste.
- The machine, accessories and packaging must be classified for environmentally friendly recycling.

# Exploded view

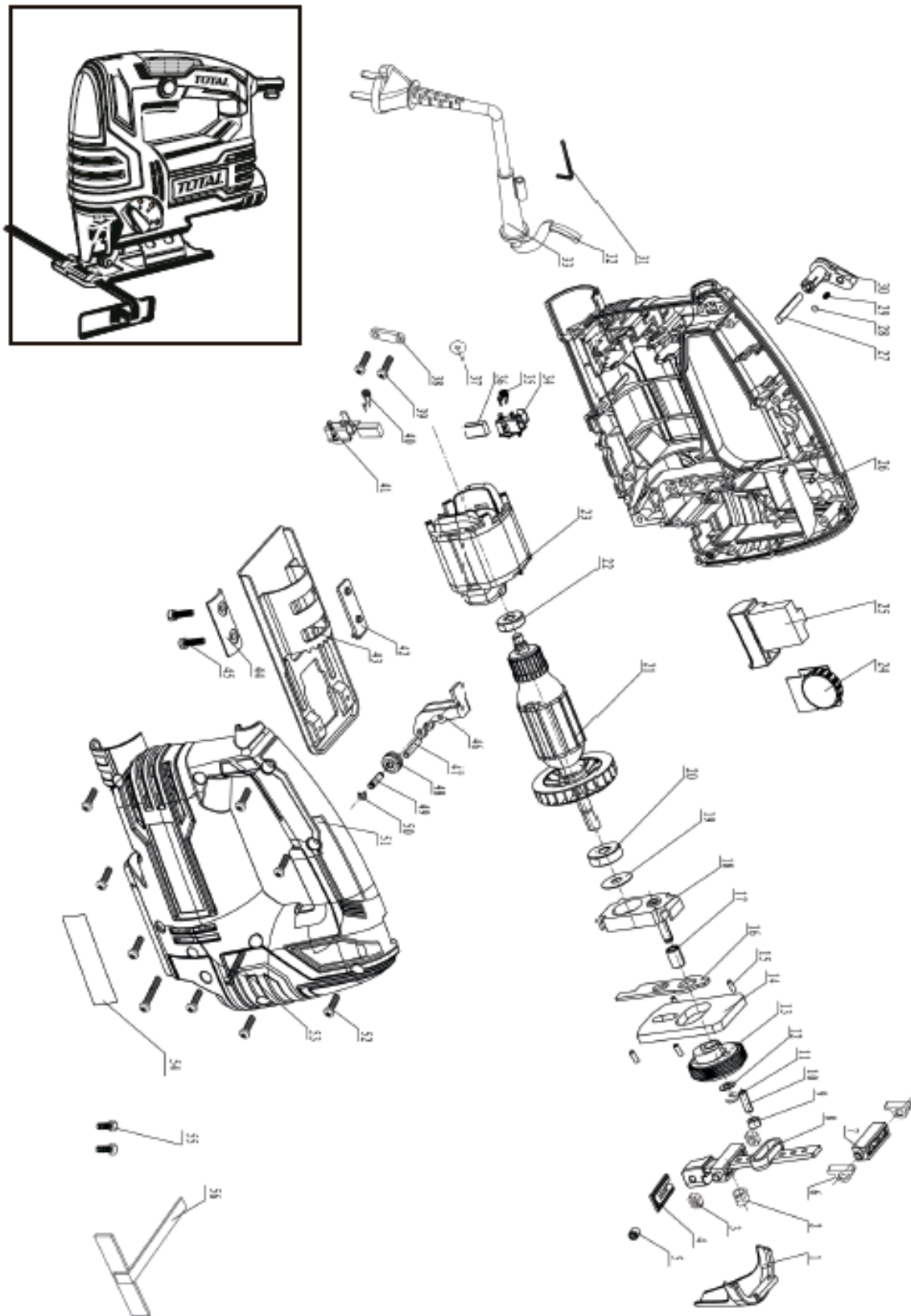

# TOTAL

One-Stop Tools Station

TOTAL



JIG SAW

570W