

# TOTAL

One-Stop Tools Station

TOTAL

## BATTERY GRINDER

TAGLI201158



# Security instructions



## Caution

Read all safety warnings and all instructions. Failure to follow all warnings and instructions may result in electrical shock, fire, and/or serious injury.

The term “power tool” in the warnings refers to your mains-operated (corded) power tool or battery-operated (cordless) power tool.

*Note: Save all warnings and instructions for future reference. Due to technical product updates, this document is subject to change without notice.*

### 1) Work area safety

- a. Keep the work area clean and well-lit to prevent accidents.
- b. Do not use power tools in explosive atmospheres, such as in the presence of flammable liquids, gases, or dust that can cause fires.
- c. Keep children and other unauthorized persons away while using a power tool. Distractions can cause you to lose control of the tool.

### 2) Electrical safety

- a. Power tool plugs must match the outlet. Never modify the plug in any way. Using a suitable plug reduces the risk of electric shock.
- b. Avoid bodily contact with grounded surfaces such as pipes, radiators, ranges, and refrigerators. There is an increased risk of electric shock if your body is grounded.
- c. Do not expose power tools to rain or wet conditions. Water entering a power tool will increase the risk of electrical shock.
- d. Never use the cord to carry, pull or unplug the power tool. Keep the cable away from heat or oil.
- e. When using a power tool outdoors, use an extension cord suitable for outdoor use.
- f. If using the tool in a damp location is unavoidable, use a Residual Current Device (RCD) protected supply to reduce the risk of electric shock.

### 3) Personal security

- a. Always stay alert, watch what you are doing and use common sense when using the tool.
- b. Do not use a power tool if you are tired or under the influence of medication or other substances.
- c. Wear personal protective equipment. Always wear eye protection. Protective equipment such as a dust mask, non-slip safety shoes, hard hat, or hearing protection used in the proper conditions will reduce personal injury. Also don't wear loose clothing or jewelry.
- d. Prevent the tool from turning on unintentionally. Make sure the switch is in the off position before connecting to power source and moving.
- e. Remove any adjusting wrenches or wrenches before turning on the power tool. An adjustable wrench or wrench placed in a rotating part of the power tool can cause serious injury.
- f. If devices are used for dust extraction and collection, make sure they are properly connected. Properly use these devices and you will reduce dust-related hazards.

#### **4) Use and care of the battery tool**

- a. Recharge the battery only with the charger specified by the manufacturer. An unsuitable charger can create a fire hazard.
- b. Use power tools only with specifically designated batteries. Use of other batteries may create a risk of injury or fire.
- c. When the batteries are not in use, keep it away from other metal objects, such as paper clips, coins, keys, nails, screws, or other small metal objects, that can make a connection from one terminal to another. Shorting the battery terminals can cause burns or fire.
- d. Abusive conditions can cause expulsion of liquid from the battery; avoid contact. If accidentally contacted, rinse immediately with water. If the liquid comes into contact with the eyes, also seek medical help. Liquid expelled from the battery can cause irritation or burns.
- e. Do not use a battery or tool that is damaged or modified. They may exhibit unpredictable behavior resulting in fire, explosion, or risk of injury.
- f. Do not expose a battery or tool to fire or excessive heat. Exposure to fire or temperature above 130°C may cause an explosion.
- g. Follow all charging instructions. Do not charge the battery or tool outside the temperature range specified in the instructions. Improper charging or charging at temperatures outside the specified range may damage the battery or increase the risk of fire.

#### **5) Service**

- a. Have your power tool serviced by a qualified person and use replacement parts recommended by the manufacturer. This will ensure that the safety of the power tool is maintained.

## Safety rules for correct use



Double insulation for additional protection



Please read the instruction manual before use.



CE conformity.



Wear safety glasses, hearing protection and a dust mask.



Waste electrical products must not be disposed of with household waste. Please recycle at the appropriate facilities. Check with your local authority or retailer for recycling advice.



Security alert. Use only accessories supported by the manufacturer.

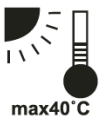

Charge the battery only below 40°C



Always recycle batteries



Do not expose the battery to fire or high temperatures



Do not expose battery to water

## Additional security warnings

### Grinding, sanding, wire brushing, polishing or abrasive cutting operations

This power tool is designed to function as a grinder, sander, planer, wire brush, polisher, or cutting tool.

Read all safety warnings, instructions, illustrations, and specifications provided with this power tool. Failure to follow all instructions may result in electrical shock, fire, and/or serious injury.

- Do not use this tool in operations for which it was not designed. Otherwise, it may create a hazard and cause personal injury.
- Do not use accessories and fixtures or tools that are not specifically designed and recommended by the tool manufacturer. The fact that the accessory can be attached to the power tool does not guarantee safe operation.
- The rated speed of the blade must be at least equal to the maximum speed marked on the power tool. A tool that has a higher speed than the tool can eject it from its clamping.
- The outside diameter and thickness of the disc must be within the rated capacity of your guards. Improperly sized accessories cannot be properly stored or controlled.
- The assembly of threaded tools must coincide with the thread of the spindle of the grinder. For flange mounted fittings, the fitting hole must fit the mounting diameter of the flange.
- Do not use the damaged cutting tool. Before each use, check the cutting discs, make sure they do not have cracks, tears or excessive wear; check wire brush for loose or cracked wires. Dull bits cause the tool to strain too much. If the power tool is dropped, inspect for damage and replace if necessary.  
After inspecting and installing a tool, stand in a safe area and check that no one is in the work area when you run the power tool at full speed with no load for one minute. Damaged accessories will normally break during this testing time.
- Wear personal protective equipment. Wear face shield, safety glasses. If necessary, dust masks, ear protectors, gloves and workshop apron capable of stopping small abrasive or chip fragments. Eye protection must be capable of stopping debris and flying particles generated by various operations. The dust mask or respirator must be capable of filtering the particles generated by your operation. Prolonged exposure to high intensity noise can cause hearing loss.
- Keep people out of the work area. Anyone entering the work area must wear personal protective equipment. Fragments of the workpiece or a broken accessory can break loose and cause injury beyond the immediate area of operation.
- Hold the power tool by insulated gripping surfaces only, when performing an operation where the tool or cutting tool may come into contact with cables and/or pipes (including its own cable). It may cause an accident or electric shock to the operator.
- Position the tool cable away from the rotating tool. If you lose control, the cable may be cut or snagged causing serious accidents.
- Never let go of the power tool until the cutting tool has come to a complete stop.
- Do not operate the power tool while carrying it by your side. Accidental contact with the disk could snag her clothing, pulling it closer to her body.
- Periodically clean the vents on the tool. The motor fan will draw dust into the casing and excessive accumulation of powdered metal can cause electrical hazards.
- Do not use the power tool near flammable materials. Sparks could ignite these materials.
- Do not use tools or cutting tools that require coolant. The use of water or other liquid coolants may result in electrocution or electrical shock.

### Rollbacks and Related Warnings

Kickback is a sudden reaction when a blade, backing pad, brush, or other cutting tool binds or snags. Binding or snagging causes a rapid lockup of the disc which, in turn, causes the uncontrolled power tool to be forced in the opposite direction of tool rotation.

Kickback is the result of power tool misuse and/or incorrect procedures or conditions. This can be avoided by taking the proper precautions.

- Keep a firm grip on the power tool to allow it to resist kickback forces. Always use the auxiliary handle, if provided, for maximum control over kickback or torque reaction during start-up. Torque reactions or kickback forces can be controlled by the operator if proper precautions are taken.
- Never put your hand near the running cutting tool. The cutting tool can kick back on your hand.
- Do not position your body in the area where the power tool will move if kickback occurs. Kickback will propel the tool in the opposite direction of wheel motion at the point of contact.
- Take special care when working around corners, sharp edges, etc. Prevent the accessory from bouncing and snagging. Corners, sharp edges, or kickback have a tendency to snag the rotating accessory and cause loss of control or kickback of the tool.

### Abrasive grinding and cutting operations

- Use only the types of discs that are recommended for your power tool and the specific guard designed for the selected wheel. Wheels for which the power tool was not designed cannot be adequately covered and are unsafe.
- The cutting surface of depressed center abrasive wheels should be mounted below the plane of the guard cutting edge. An incorrectly mounted wheel that protrudes beyond the plane of the guard edge cannot be adequately protected.
- The guard must be firmly attached to the power tool.
- Discs should only be used for recommended applications.
- Always use the proper flanges for the correct size and design of discs. Flanges for cutting wheels may be different from flanges for grinding wheels.
- Do not use worn wheels from larger power tools. The blade intended for a larger power tool is not suitable for the higher speed of a smaller tool.

### Abrasive cutting operations

- Do not "jam" the disc or apply excessive pressure. Overloading the disc increases susceptibility to binding and the possibility of kickback or breakage.
- Do not place the body near the cutting area of the disc. When the wheel locks up at the point of contact and in the event you stomp, that kickback will direct the tool toward your body.
- When the blade jams for any reason, turn off the tool and hold it still until it comes to a complete stop. Never try to remove the cutting disc by turning the tool on again, otherwise kickback may occur. Investigate and take corrective action to eliminate cause of stall.
- Do not restart the cutting operation on the workpiece. Let the blade come up to full speed and carefully recut. The wheel can bind, ride up, or kick back if the power tool is restarted on the work piece.
- Any large work piece should be clamped with the proper clamps to minimize the risk of binding. Supports, clamps, "C" clamps, clamps or "F" clamps must be placed on the edges of the workpiece at a safe and prudent distance from the line of cut or gouging to be made.
- Use extreme caution when making a "pocket cut" in existing walls or other blind areas. It may cut gas or water pipes, electrical wiring, or objects that can cause kickback.

## Sanding operations

- Do not use oversized discs. Follow the manufacturer's recommendations when selecting sandpaper. Sandpaper that extends past the sanding pad presents a hazard and can cause binding and kickback.

## Polishing operations

- Do not allow the residue of any polishing flecks to spin freely. Please remove or clip them because otherwise they may harm the work or your own body.

## Wire brushing operations

- Please note that the brush sheds wire bristles even during normal operation. Do not overload the cables by applying excessive load to the brush. Wire bristles can easily penetrate light clothing and/or skin.
- The use of a wire brush guard is recommended. The wire wheel or brush may expand in diameter due to work load and centrifugal forces.

# Other warnings

## Save these instructions



### Attention

Do not let comfort or familiarity with the product (gained from repeated use) replace strict adherence to safety rules for the product in question. Incorrect use or non-compliance with the safety rules indicated in this instruction manual can cause serious personal injury.

## Symbols

The symbols used for the tool are shown below.

symbols	
<b>V</b>	volts
<b>— ... —</b>	DC
<b>n</b>	Nominal speed
<b>n<sub>0</sub></b>	no load speed
<b>... /min r/min</b>	Revolutions per minute

## Important safety instructions for the battery cartridge

1. Before using the battery, read all instructions and cautionary markings on:
  - a. The battery charger
  - b. Drums
  - c. Product.
2. Do not disassemble the battery cartridge.
3. If the operating time has been shortened excessively, stop using it immediately. It can result in overheating, possible burns, and even an explosion.

4. If electrolyte gets into your eyes, flush with clean water and seek immediate medical attention. It can result in loss of sight.
5. Do not short circuit the battery cartridge:
  - a. Do not touch the terminals with any conductive material
  - b. Avoid storing the battery cartridge in a container with other metallic objects such as nails, coins, etc.
  - c. Do not expose the battery cartridge to water or rain.  
*Note: A short circuit in the battery can cause a large current flow, overheating, possible burns and even a breakdown.*
6. Do not store the tool or battery cartridge where the temperature may reach or exceed 50°C (122°F).
7. Do not incinerate the battery cartridge even if it is badly damaged or completely spent. The battery cartridge may explode in case of fire.
8. Be careful not to drop or hit the battery.
9. Do not use a damaged battery.
10. Follow local regulations regarding battery disposal.

### Tips for maintaining maximum battery life

1. Charge the battery cartridge before it is fully discharged. Always stop tool operation and charge the battery cartridge when you notice less power from the tool.
2. Never recharge a fully charged battery. Overcharging shortens battery life.
3. Charge the battery cartridge at room temperature 10°C to 40°C (50°F to 104°F). Let a hot battery cartridge cool down before charging it.
4. Charge the battery cartridge if you do not use it for a long time (approx. more than six months).

## Other risks

Even when the power tool is used as prescribed, it is not possible to eliminate all residual risk factors:

- a. Health defects resulting from vibration emission if the power tool is used for a longer period of time or if it is not managed and maintained properly.
- b. Injuries and property damage due to broken fixtures breaking suddenly.



### Caution

This power tool produces an electromagnetic field during operation. This field can, in some circumstances, interfere with active or passive medical implants.



To reduce the risk of serious injury, we recommend that persons with medical implants consult their physician before using this power tool.

If the cable is damaged or cut during work, do not touch the cable, immediately unplug the tool. Never use the machine with a damaged cable.

The machine must not be damp and must not be used in a humid environment.





### Attention

Safe operation of this machine is only possible when the operating or safety information is fully read and the instructions contained therein are strictly followed.



## Technical data

Data sheet	
<b>Voltage</b>	20V
<b>no load speed</b>	3000 - 8500/min
<b>Disc diameter</b>	115mm
<b>Spindle thread</b>	M14

## Assembly and installation working

### Functioning



#### Attention

Always make sure the tool is turned off and the battery cartridge is removed before adjusting or checking the function on the tool.

### Installing or removing the battery cartridge



1. Button

2. Battery cartridge

#### Attention



- Always turn off the tool before installing or removing the battery cartridge.
- Hold the tool and battery cartridge firmly when installing or removing the battery cartridge. Failure to hold the tool and battery cartridge firmly can cause them to slip out of your hands, resulting in damage to the tool and battery cartridge and personal injury.

To remove the battery cartridge, slide it out of the tool while pressing the button on the front of the cartridge.

To install the battery cartridge, align the tab on the battery cartridge with the slot in the casing and slide it into place. Insert it all the way until it clicks into place with a small click. If you can see the red indicator at the top of the button, it's not completely locked.



### Attention

- Always install the battery cartridge completely until the red indicator cannot be seen. Otherwise, it may accidentally fall off the tool and injure you or someone around you.
- Do not install the battery cartridge forcibly. If the cartridge does not slide in easily, it is not being inserted correctly.
- Before installing the battery cartridge into the tool, always check that the slide switch actuates properly and returns to the "OFF" position when the rear of the slide switch is pressed.
- The switch can be locked in the "ON" position to facilitate operator comfort during extended use. Take care when locking the tool in the "ON" position and hold the tool firmly.

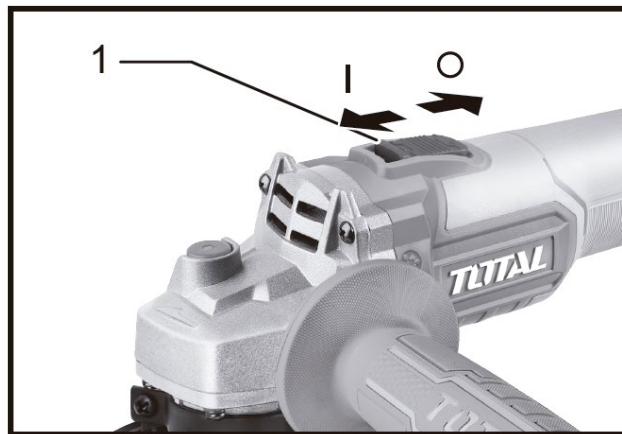

1. Slide switch

To start the tool, slide the slide switch to the "I" (ON) position by pressing the rear of the slide switch. For continuous operation, press the front of the slide switch to lock it.

To stop the tool, press the rear of the slide switch and then slide it to the "O" (OFF) position.

### Accidental restart prevention function

Even if the battery cartridge is installed in the tool with the slide switch in the "I" (ON) position, the tool will not start. To start the tool, first slide the slide switch to the "O" (OFF) position and then slide it to the "I" (ON) position.

### Spindle lock

Never engage the spindle lock when the spindle is moving. The tool may be damaged.

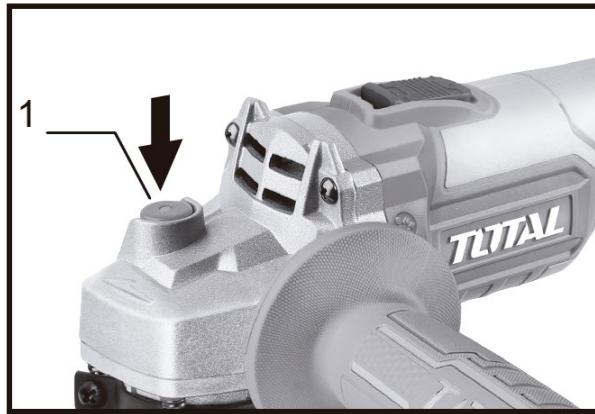

1. Spindle lock

Press the spindle lock to prevent spindle rotation when installing or removing accessories.

### Mounting

#### **Attention**

Always make sure the tool is switched off and the battery cartridge is removed before carrying out any work on the tool.



### Installation of the auxiliary handle

#### **Attention**

Always make sure the side handle is securely installed before operation.



Firmly screw the side grip into the position of the tool as shown in the figure.

*Note: This handle must be used at all times to maintain full control of the tool.*

Installing or removing the blade guard (for depressed center blade, abrasive/multi-disc cut-off wheel, diamond blade)

#### **Attention**

- When using a depressed center/multi-disc grinding wheel, wire wheel brush, cut-off wheel, or diamond wheel, the wheel guard must be installed on the tool so that the closed side of the guard always faces towards the operator.
- When using an abrasive diamond / cut-off wheel, be sure to use only the special blade guard designed for use with cut-off wheels.



### For tool with clamping lever type wheel guard

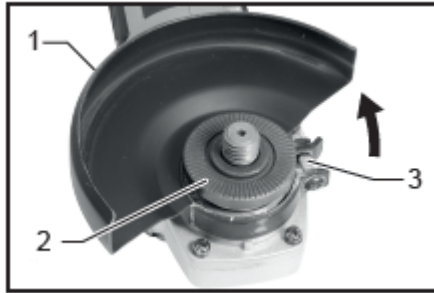

- 1. Disc guard
- 2. Bearing housing
- 3. Screw

- Loosen the blade guard lever after loosening the screw.
- Mount the blade guard with the projection on the blade guard band aligned with the notch in the bearing housing.
- Then rotate the blade guard to an angle such that it can protect the operator depending on the job.

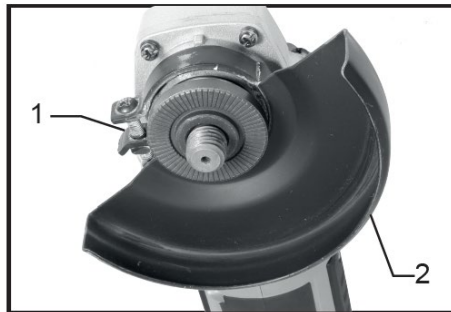

- 1. Screw
- 2. Disc guard

- Squeeze the lever to hold the blade guard.
- If the lever is too tight or too loose to hold the guard, loosen or tighten the screw to adjust the tightness of the blade guard band.
- To remove disk protection, follow the installation procedure in reverse

### For tool with locking screw type wheel guard

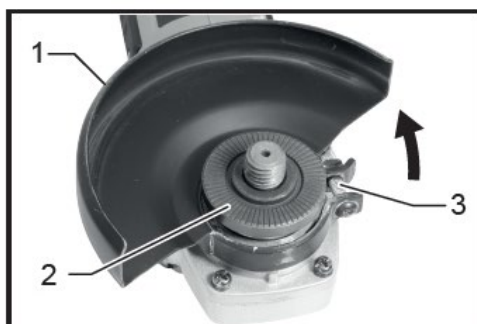

- 1. Disc guard
- 2. Bearing housing
- 3. Screw

- Mount the blade guard with the protrusions on the blade guard band aligned with the notches in the bearing frame.
- Then rotate the wheel guard about 180° counterclockwise.
- Be sure to firmly tighten the screw.
- To remove disk protection, follow the installation procedure in reverse.

## Disc mounting (optional accessory)



### Attention

When using a depressed center wheel or multiple wheel, the wheel guard must be installed on the tool so that the closed side of the guard always faces the operator.

- Engage the spindle lock only when the spindle is not moving.

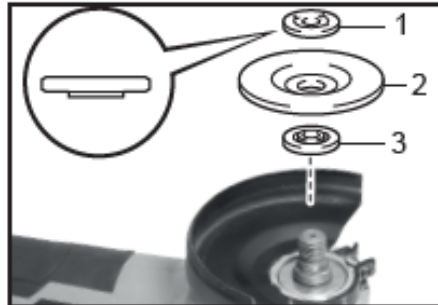

1. Lock nut
2. Depressed center wheel
3. Inner flange

- Mount the inner flange on the shaft.
- Place the wheel/disc on the inner flange and screw the locknut onto the axle.

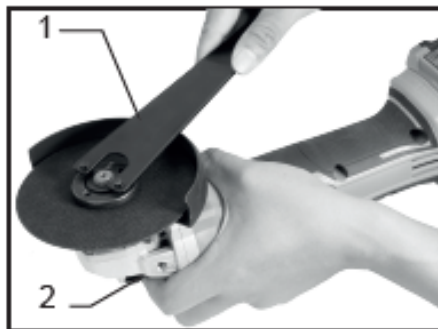

1. Locknut wrench
2. Spindle lock

- To tighten the locknut, firmly press the spindle lock so that the spindle cannot rotate, then use the locknut wrench and firmly tighten clockwise.
- To remove the wheel, follow the installation procedure in reverse.

## Installation or removal of abrasive disc (optional accessory)

- Mount the rubber pad on the shaft.
- Place the disc on the rubber pad and screw the locknut onto the spindle.
- To tighten the locknut, press firmly on the spindle lock so that the spindle cannot rotate
- Then use the lock nut wrench and tighten securely in a clockwise direction.
- To remove the drive, follow the installation procedure in reverse.

*Note: Use sander accessories specified in this manual. They must be purchased separately.*

## To use the sander

- It should never be necessary to force the tool. The weight of the tool applies adequate pressure. Excessive force and pressure can cause dangerous disc breakage.
- Always replace the wheel if the tool is dropped during grinding.
- Never hit the disc or grinding wheel against the work.
- Prevent the blade from bouncing and snagging, especially when working around corners, sharp edges, etc. This can cause loss of control and kickback.

- Never use tools with wood cutting attachments or other saw blades. Such blades, when used on a grinder, frequently kick and cause loss of control and personal injury.



### Attention

- Never start the tool when it is in contact with the work piece, it may cause injury to the operator.
- Always wear safety glasses or a face shield during operation.
- After operation, always turn off the tool and wait until the blade has come to a complete stop before putting the tool down.

### Polishing and sanding operation

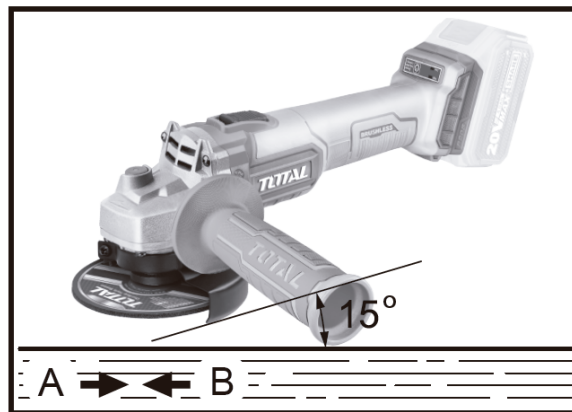

- Always hold the tool firmly with one hand on the housing and the other on the side handle. Turn on the tool and then apply the wheel or disc to the work piece.
- In general, keep the edge of the blade or disc at an angle of about 15 degrees to the surface of the workpiece.
- During the break-in period with a new wheel, do not work the grinder in direction B or it will cut the workpiece.
- Once the edge of the wheel has rounded off with use, the wheel can be worked in both the A and B directions.



### Attention

- When using an abrasive diamond / cut-off wheel, be sure to use only the special blade guard designed for use with cut-off wheels.
- Never use a cut-off wheel for side grinding.
- Do not "jam" the disc or apply excessive pressure. Do not try to cut too deep. Overloading the blade increases the load and susceptibility to twisting or binding the blade in the cut and the potential for kickback, blade breakage and motor overheating can occur.
- Do not start the cutting operation on the work piece. Allow the wheel to come up to full speed and carefully enter the cut by moving the tool forward over the surface of the workpiece. The blade can bind, ride up, or back up if the power tool is started on the workpiece.
- During cutting operations, never change the angle of the blade. Applying side pressure to the cutting blade (as in grinding) will cause the blade to crack and break, resulting in serious personal injury.
- A diamond blade should be used perpendicular to the material being cut.

## Operation with abrasive parting / diamond disc (optional accessory)

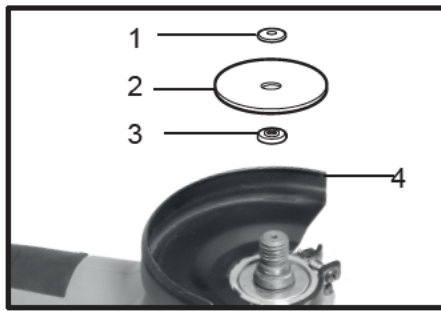

1. Locknut
2. Abrasive cutting disc/diamond disc
3. Inner flange
4. Disc guard for abrasive cutting disc/diamond disc

- Remove the battery cartridge from the tool and turn it upside down to allow easy access to the spindle.
- Mount the inner flange and abrasive cut-off/diamond wheel on the spindle.
- Tighten the locknut securely with the supplied wrench.
- The direction to mount the lock nut and inner flange varies depending on the thickness of the disc.

## Wire cup brush operation (optional accessory)

### Attention



- Check brush operation by running tool without load, making sure no one is in front of or in line with brush.
- Do not use a damaged or unbalanced brush. Using a damaged brush could increase the possibility of injury from contact with broken brush wires.

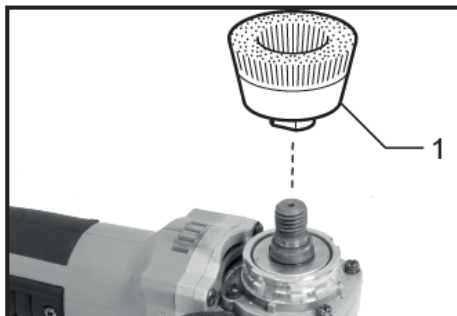

1. Wire cup brush

- Remove the battery cartridge from the tool and turn it upside down to allow easy access to the spindle.
- Remove all accessories from the spindle.
- Thread the wire cup brush onto the spindle and tighten with the wrench provided.
- When using a brush, avoid applying too much pressure, which causes the wires to bend too far and break prematurely.

## Operation with circular wire brush (optional accessory)

### Attention



- Check wire wheel brush operation by running tool without load, making sure no one is in front of or in line with wire wheel brush.
- Do not use a damaged or unbalanced wire wheel brush. Using a damaged wire wheel brush could increase the chance of injury from contact with broken wires.
- Always use the guard with wire wheel brushes, making sure the diameter of the wheel fits inside the guard. The circular brush can break during use and the guard helps reduce the chance of personal injury.

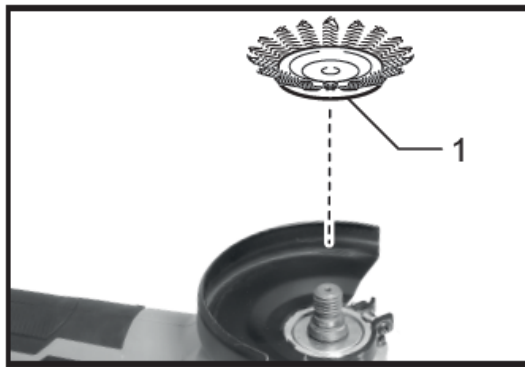

1. Wire circle brush

- Remove the battery cartridge from the tool and turn it upside down to allow easy access to the spindle.
- Remove all accessories from the spindle.
- Thread the wire wheel brush onto the spindle and tighten with the wrenches.
- When using a circular wire brush, avoid applying too much pressure, which causes the wires to bend too much and break prematurely.

## Maintenance and troubleshooting

### Maintenance

Make sure the tool is unplugged from power before performing any maintenance.

- Keep the ventilation slots clean and free of obstructions. If possible, blow compressed air into the vents to remove internal dust (safety glasses should be worn when doing this).
- Keep the outer casing of the tool clean and free of grease. Do not wash with water or use solvents or abrasives. Use only mild soap and a damp cloth to clean the tool. Never let liquid get inside the tool. Never immerse any part of the tool in liquid.
- Always store your power tool in a safe, dry place.
- If you see some small sparks flashing from the ventilation slots, this is normal and will not damage your power tool.

### Problem solving

Although your grinder is actually very simple to use, if you experience problems, check the following:

- If it is not working, check the level of charge in the battery.
- If the disc wobbles or vibrates, check that the outer flange is tight; check that the disc is correctly positioned on the flange plate.
- If there are signs that the disc is damaged, do not use it as the damaged disc may disintegrate, remove it and replace it with a new one. Dispose of old discs correctly and responsibly.
- If working with aluminum or the like, the disc will soon clog and will not sand effectively.

*Note: If you cannot find the fault, contact your official Total dealer.*



## Environment



- Do not dispose of electrical appliances as unsorted municipal waste, use separate collection facilities.
- Contact your local authority for information on available collection systems.
- If electrical appliances are disposed of in landfills, hazardous substances can seep into the groundwater and enter the food chain, harming your health and well-being.
- Recycle raw materials instead of disposing of them as waste.
- The machine, accessories and packaging must be sorted for environmentally friendly recycling.

## Exploded view

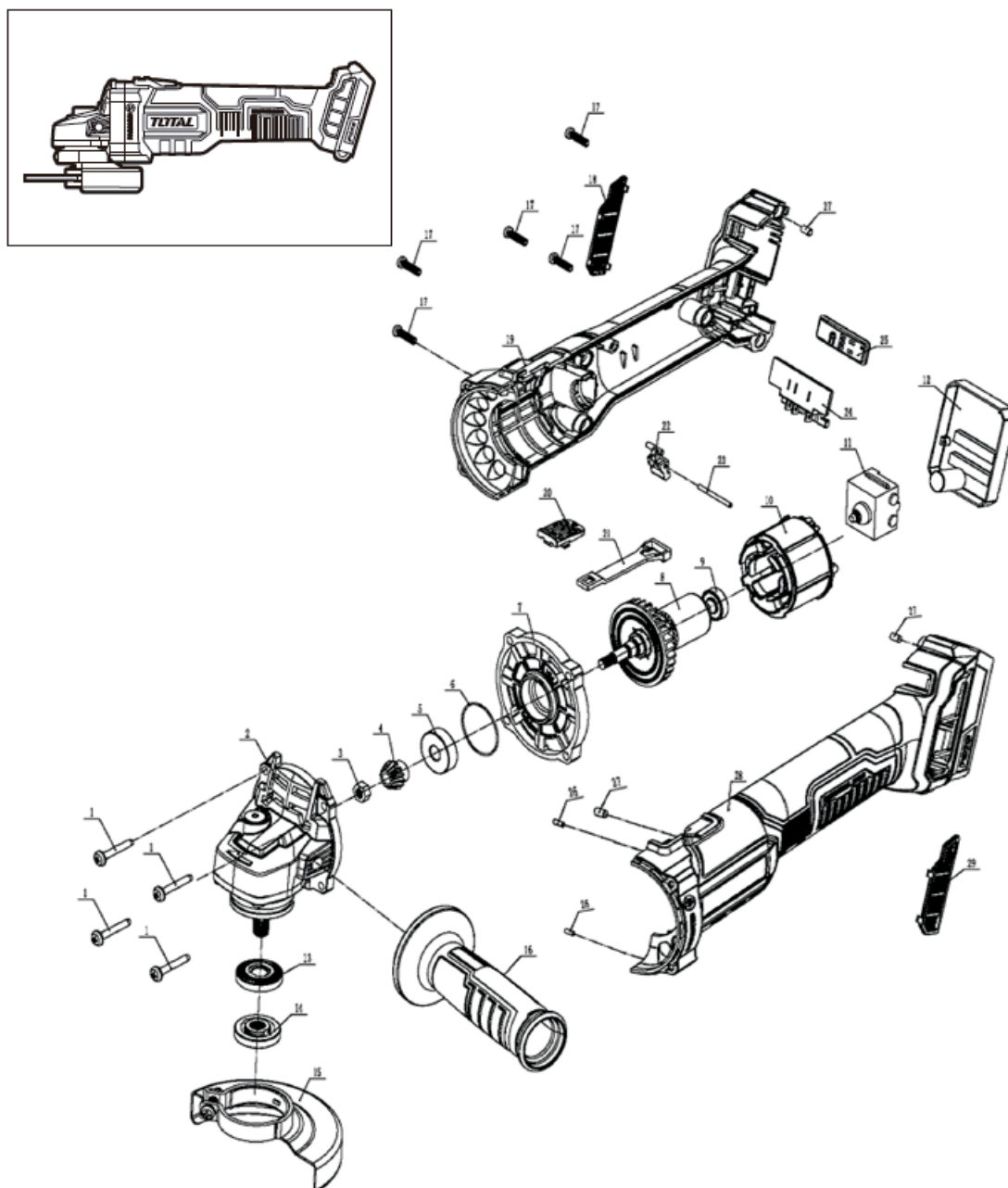

# TOTAL

One-Stop Tools Station

TOTAL

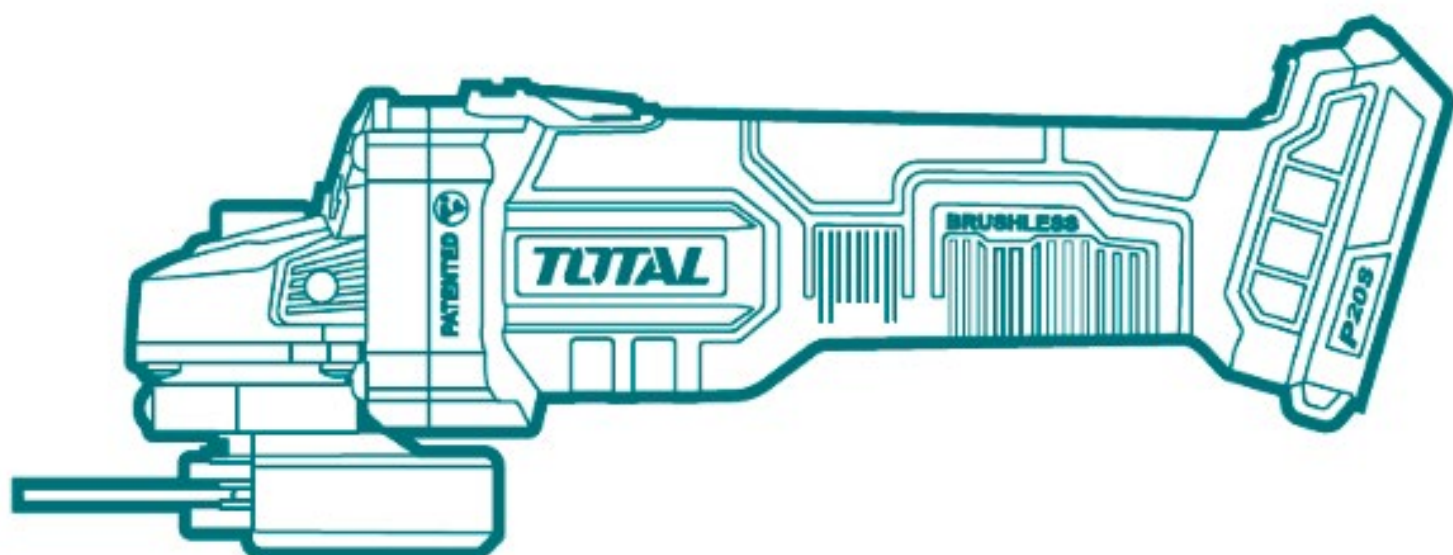

**BATTERY GRINDER**